

## Compact Linear Systems

Modular and Comprehensive Solutions for Space-Conscious Applications



## Let's Build Your Ideal Linear Solution

Specifying multiple components for a linear motion system design can sometimes come with obstacles – delays, misapplications, additional costs and a general uncertainty about your selections just to name a few. Take the guesswork out of this process with Thomson compact linear systems. You'll be able to work closely with our experts to mix and match our trusted components for a tailor-fit solution.

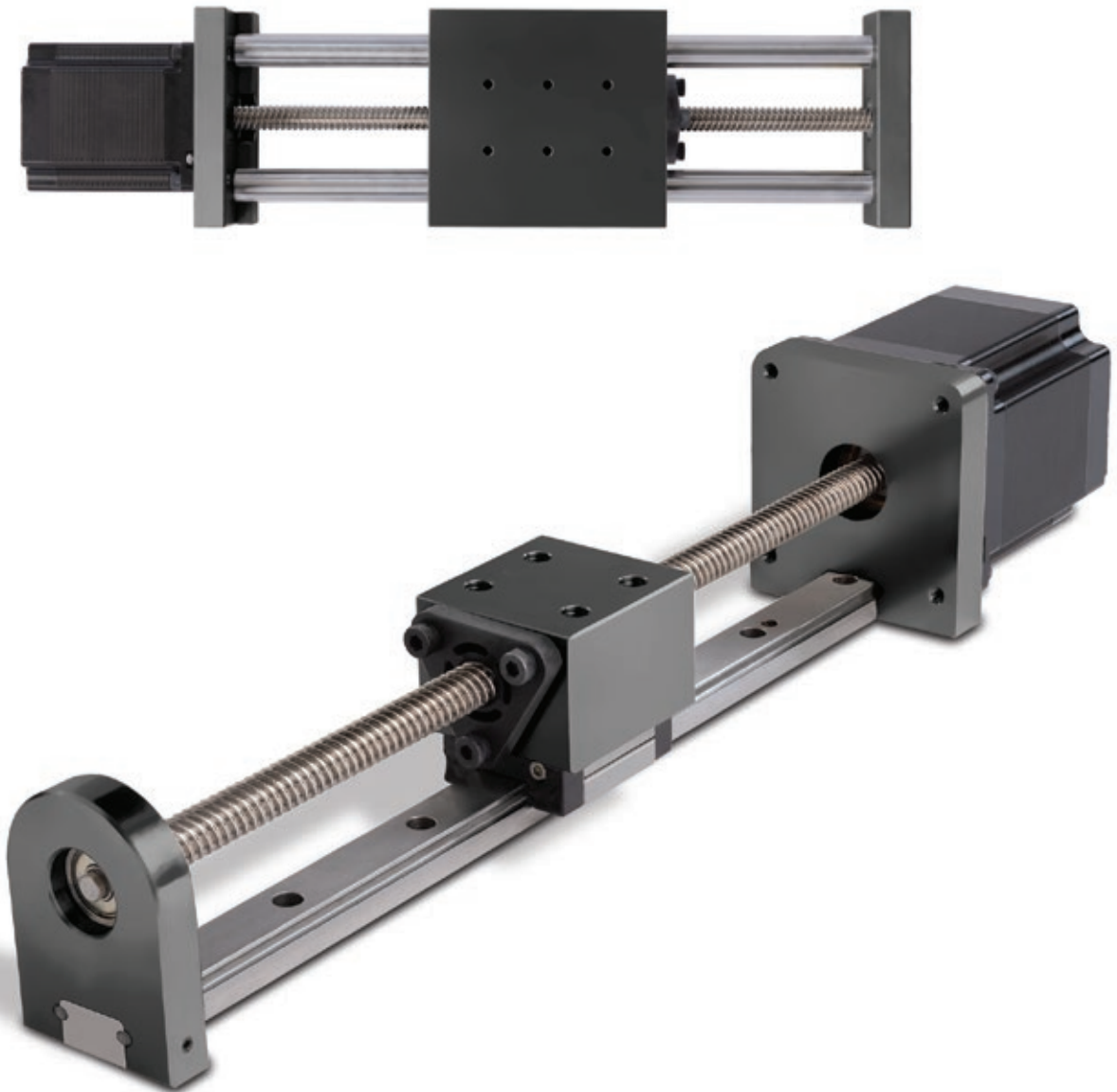

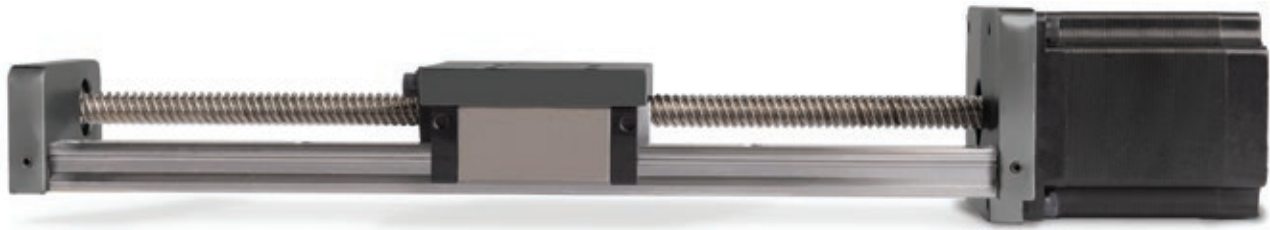

### Modular To Match Your Needs

With our compact linear systems, there is no “one size fits all” model. Your application requirements will determine the selection and sizing of components that go into configuring your ideal solution.

- Choose from our wide standard offering of lead screws, linear bearings, guides and more.
- If one of our three standard architectures (see next page) don’t meet your design specifications, we can work with you on a completely “from scratch” system.
- Mounting blocks can be machined to virtually any shape or size.

### Consult With Us On Your Design

No matter how simple or complex your system requirements, you can take advantage of a virtual design consultation with a Thomson application engineer. It’s like having a linear motion expert by your side as you build your solution.

- Our application engineers are familiar with working in a 3D CAD environment and bring decades of expertise to your design project.
- Your compact linear system project isn’t considered complete until you are 100% satisfied.

### Shorten Your Design Cycle

With our experts’ knowledge of Thomson components and a virtual design consultation focused on getting your compact linear system right the first time, you can rest easy knowing your project’s timeline will remain on track.

- Systems can be produced and delivered quickly due to the automation of back-end modularity processes (populating drawings, computing machining requirements, etc.).
- Tailor your compact linear system up front with attachments and mounting holes to integrate into your existing machine design.
- A 3D model of your system is made available to you in real time or typically within one business day.



## Standard Configuration Options

After decades of working closely with customers and learning which solutions best meet their application needs, we've utilized our knowledge to configure three linear system options to cover most design requirements.

### Narrow/Vertical Configuration (CLSV)

Achieve a smaller footprint by vertically stacking the screw and profile rail bearing.

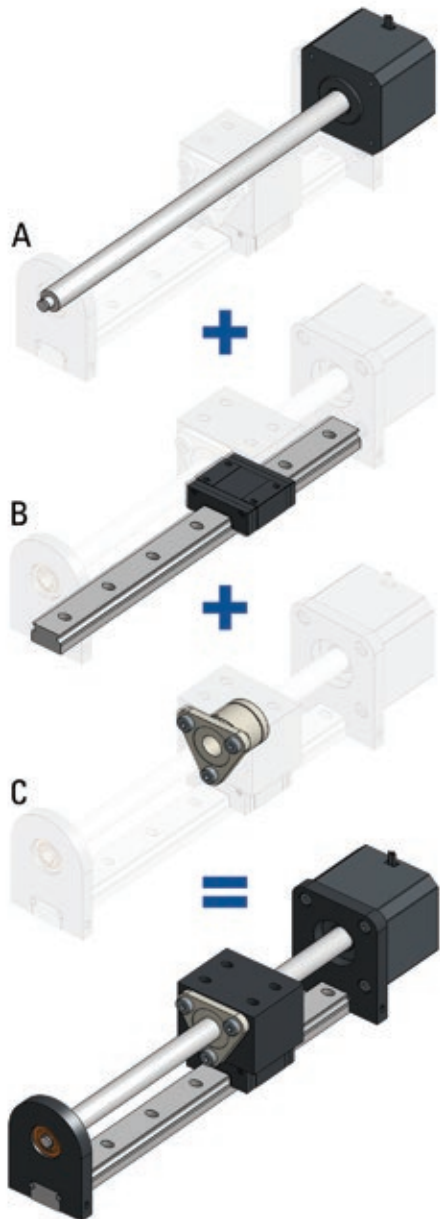

A. Thomson lead screw and motor (MLS)  
B. Thomson profile rail and carriage  
C. Thomson anti-backlash nut.

### Wide/Horizontal Configuration (CLSH)

Achieve a shorter system height by horizontally arranging the lead screw and profile rail bearing.

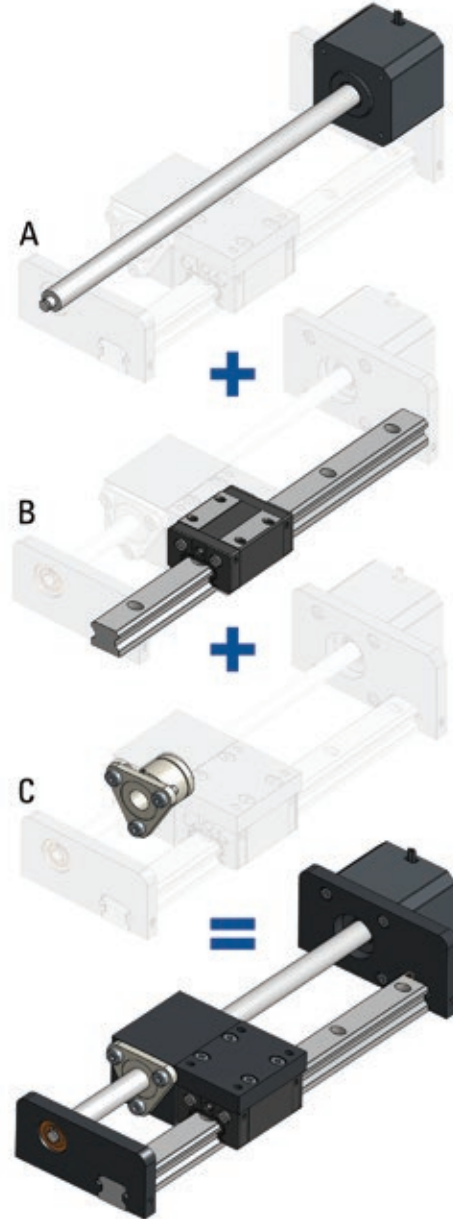

A. Thomson lead screw and motor (MLS)  
B. Thomson profile rail and carriage  
C. Thomson anti-backlash nut.

## Round Rail Configuration (CLSR)

Achieve a cost-effective solution capable of withstanding high moment loading by using a dual round rail guidance system.

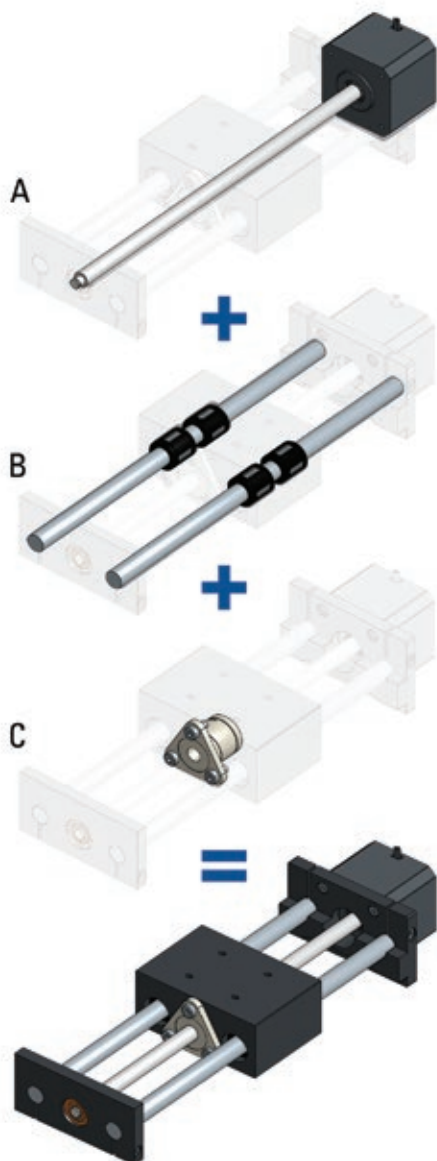

A. Thomson lead screw and motor (MLS)  
 B. Thomson 60 Case® round rail and linear bearings  
 C. Thomson anti-backlash nut.

## Linear System Design Tips

Consider the environmental conditions under which the system will operate, including temperatures, dust and dirt levels, chemical exposure, washdown processes, vibration and shock load, and radiation.

When defining the direction and magnitude of your load, the system orientation can be important. With a horizontal orientation, the drive load is equal to the payload weight times the frictional coefficient, while with a vertical orientation, the drive load is equal to the weight.

For applications that require accurate positioning, the mounting surface of the rail can be machined.

Lead screw drives, which are used in low to medium duty cycle positioning applications, operate at low noise levels and provide excellent repeatability of 0.005 mm

Purchasing a configured linear motion system can typically reduce engineering time and assembly cost by 90% or more, while providing a 20-30% cost savings in material.



## Linear Motion Solutions Your Way

With more than 75 years of experience in solving linear motion challenges, Thomson engineers understand that not every design or application is straightforward. Considerations such as spatial requirements, harsh environments or conditions, and heavy or unbalanced loads can significantly affect component selection and sizing. Our engineers also appreciate that design engineers often have to work on tight timelines. All of these factors were top of mind when developing Thomson compact linear systems.

### Compact Linear System Components

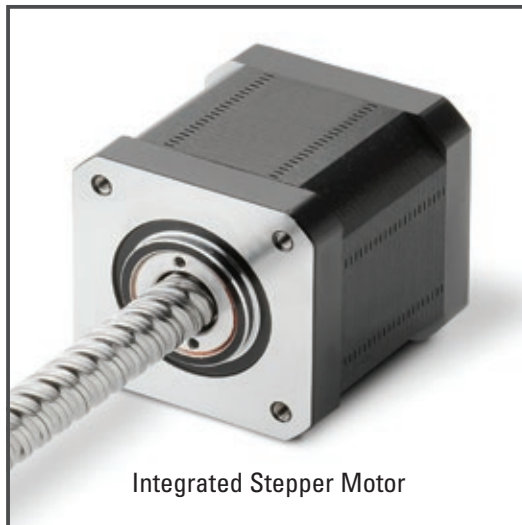

#### Why a Profile Rail System?

Also known as “square” rail, this technology has a higher load capacity and much tighter accuracy than round rail. Its compactness can help reduce the overall size of the system, but higher preloads can increase in drag. Profile rail’s unforgiving design can either benefit or complicate your design. For instance, the mounting and installation process can be a challenge if poor parallelism is a factor.



Given our collaborative and thorough approach to helping you reach your ideal compact linear system, you might assume this level of customer service comes at a premium. However, you'll be pleased to know that these configurable systems have been created to maximize efficiencies in not only time and accuracy but cost as well. You won't need to waste time listening to sales pitches. Thomson application engineers' only concern is solving your design challenges with the ideal compact linear system.

In building a Thomson compact linear system, you can configure a unit or combination of units from a wide variety of components based on your specific application requirements.



### Why a Round Rail System?

While this technology has a lower load capacity and looser accuracy, it provides a smooth and low drag platform. The only option for end-supported applications, round rail is self-aligning and forgiving of issues that arise from poor parallelism or variation in rail height for systems utilizing multiple rails. Its simplistic profile boasts highly effective sealing and a natural contamination resilience.





# Design Your Compact Linear System in Four Easy Steps

Whether your application requirements lead you to choosing a standard or tailor-made Thomson compact linear system, our engineers are ready to work alongside you to discover your ideal solution. Here's how it works:

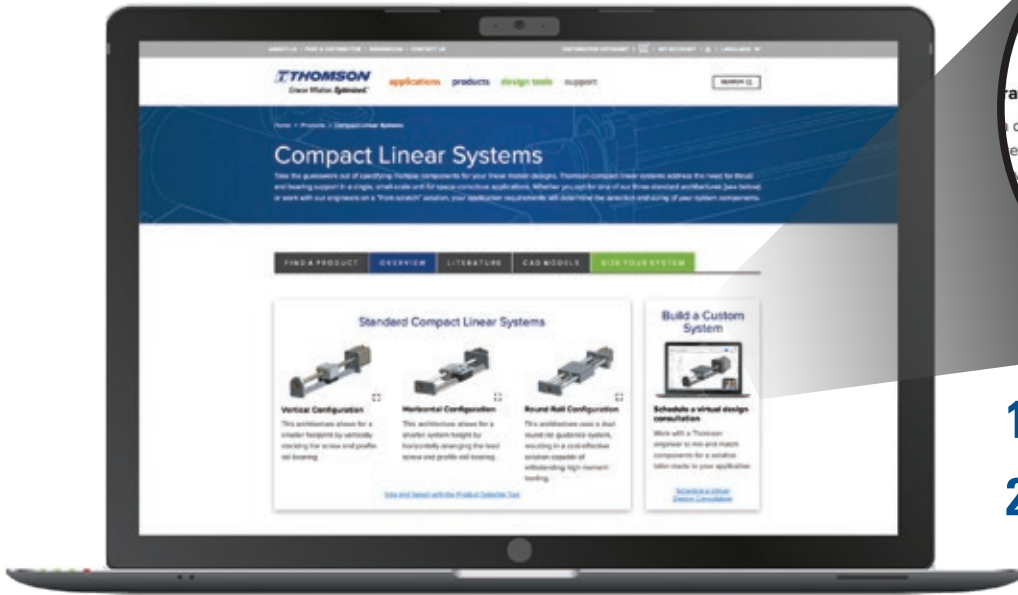

- 1 Visit [www.thomsonlinear.com/cls](http://www.thomsonlinear.com/cls)
- 2 Click "Schedule a Virtual Design Consultation"

3 A Thomson engineer will join you on a live session to design and optimize your solution

4 Review a CAD model during or after the session

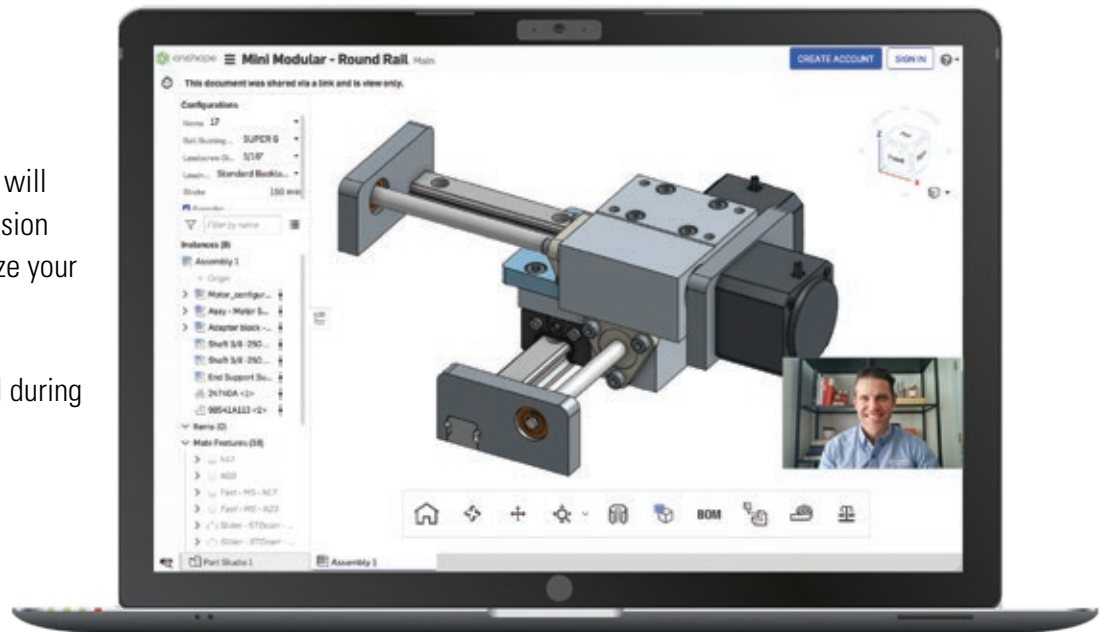

**OR**

Use our online product selector tool to narrow your choices from our large selection of predesigned linear motion systems.

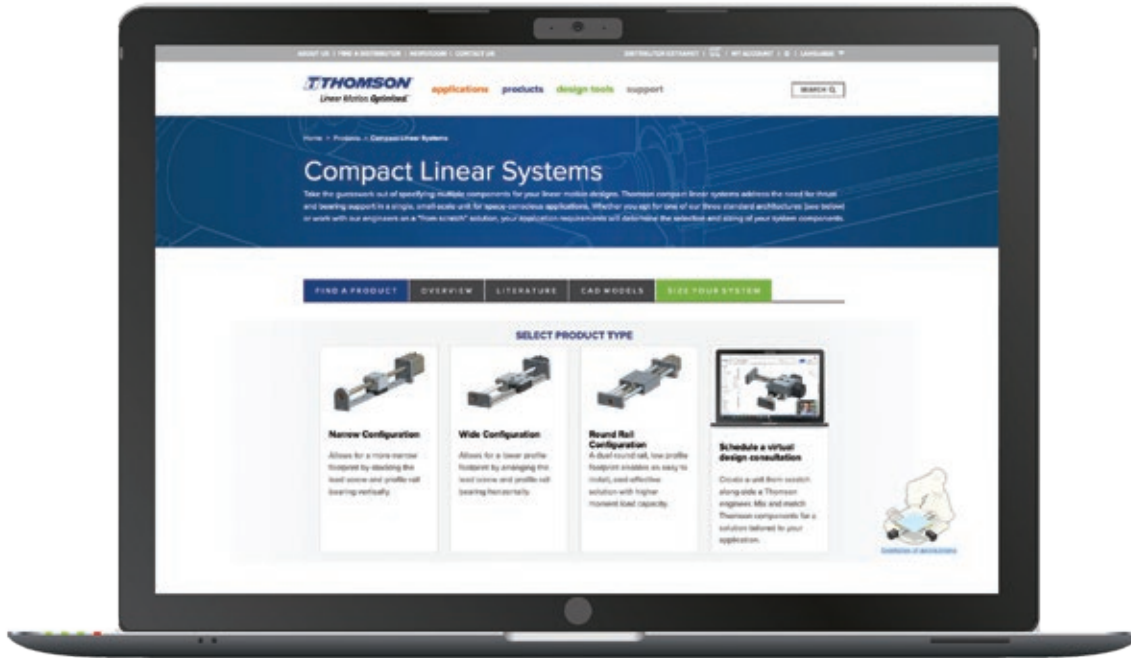

## Your compact linear system solution is only minutes away

Following months of development, the compact linear system online selector tool is ready to simplify your search and selection process, and help you quickly identify the right solution for your application.

- Access new, verified 3D models, catalog links and product details.
- Visual selection process immediately narrows your compact linear system search.
- Up-front lead times and prices are listed with the option to purchase.
- Real-time adjustments per your defined filter parameters.
- “Recommended Products” are provided based on the applications expertise of Thomson engineers.



## Application Examples

Thomson compact linear systems are ideal for applications requiring high-accuracy linear axes in confined spaces, such as 3D printers, semiconductor manufacturing, microscope stage positioners and many other medical devices. Below are just a few examples.

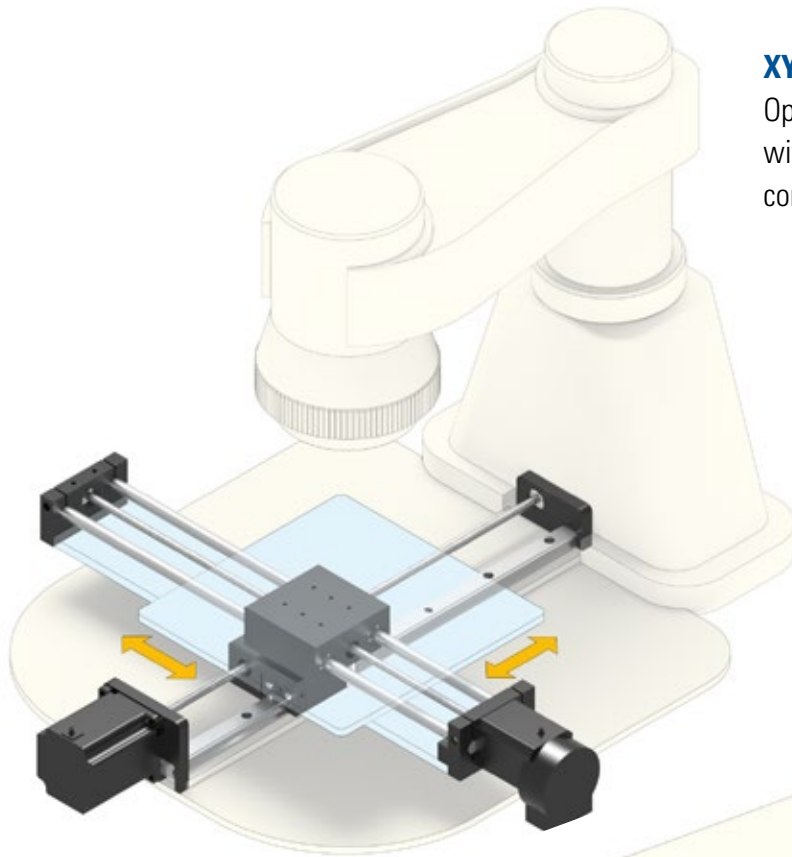

### XY Stages

Optimize XY stage designs with compact linear systems' compactness and power.

### Pipetting

Tiny, precise and repeatable vertical motion is essential for pipetting. Choose compact linear systems to simplify your z-axis and for accurate horizontal motion.

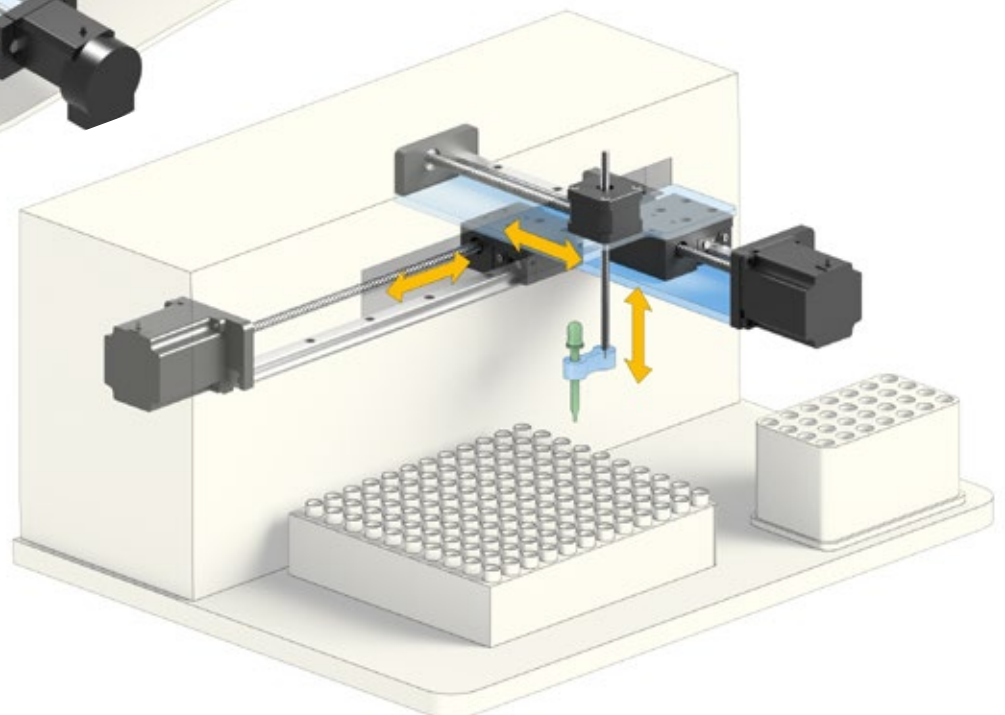

## Key Markets

## MEDICAL



## SECURITY - MILITARY



## PACKAGING

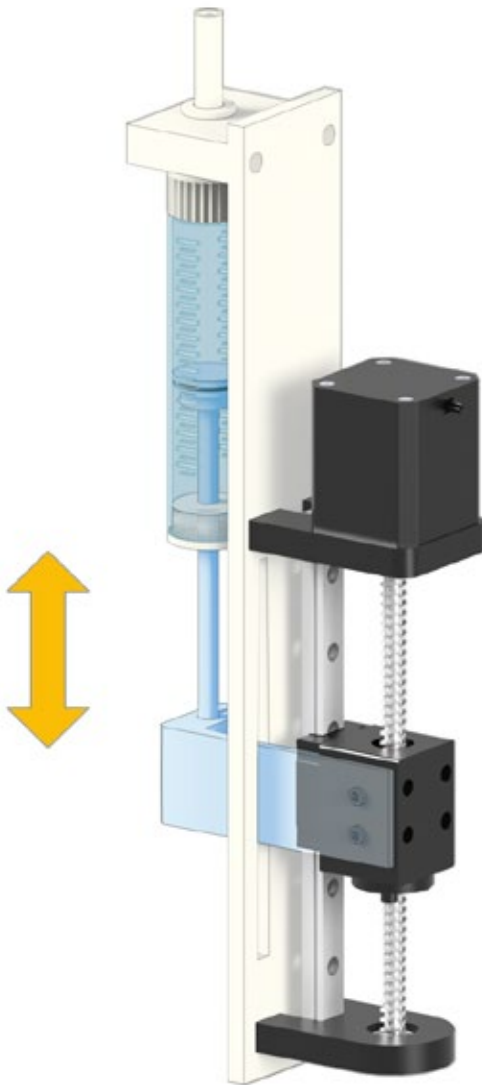

## SEMICONDUCTOR

**Fluid Pumps**

Compact linear systems can increase pump pressure, reduce equipment footprint and more accurately disperse fluid.



# Technical Specifications

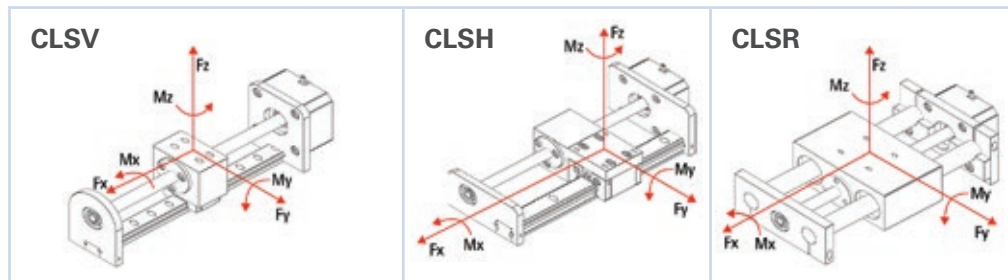
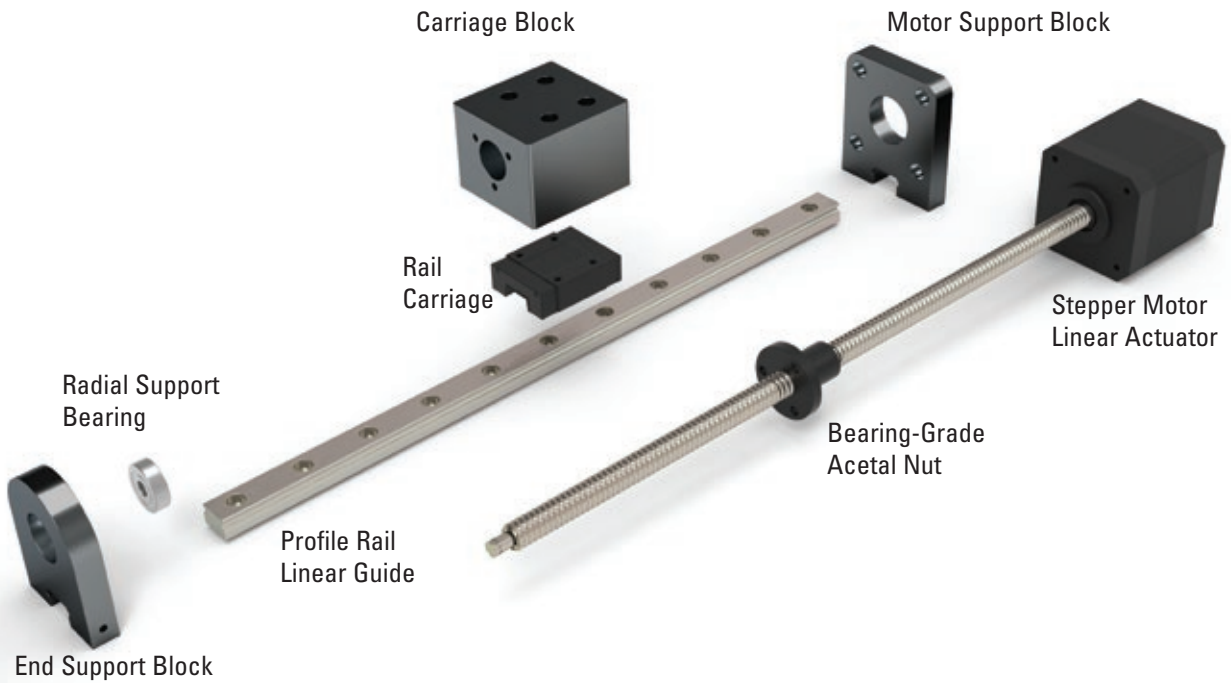

Thomson Guide	CLSV				CLSH	CLSR		
	Microguide 9	Microguide 12	Microguide 15	400 Series Size 15		400 Series Size 15	4x Super6	4x Super8
Stepper Motor	NEMA14	NEMA14/ NEMA17	NEMA17/NEMA23		NEMA17/NEMA23	NEMA17/NEMA23		
Max Stroke Length* [mm]	500	500	600	800	800	400	500	500
Max Load (Fx) [N]	220	346	711	890	890	890	890	890
Max Load (Fy)** [N]	250	284	583	1,254	2,000	200	400	500
Max Load (Fz)** [N]	200	500	1,250	2,000	2,000	200	400	500
Roll Moment (Mx)** [Nm]	10	11	22	48	48	12	26	33
Pitch Moment (My)** [Nm]	5	6	12	41	41	7	19	24
Yaw Moment (Mz)** [Nm]	5	6	13	41	41	7	19	24

\*Longer strokes are available with lower load capacities - Please contact Thomson

\*\*The dynamic load and moment ratings are based upon 127 km travel life

# Ordering Key

Compact Linear Systems																		
1	2	3	4	5	6	7	8	9	10	11	12	13	14	15	16	17	18	
<b>CLSV</b>	<b>14</b>	<b>A</b>	<b>13</b>	<b>-</b>	<b>31</b>	<b>0500</b>	<b>S</b>	<b>06000</b>	<b>N</b>	<b>-</b>	<b>X</b>	<b>MT</b>	<b>2</b>	<b>P</b>	<b>09</b>	<b>A</b>	<b>0</b>	<b>XX</b>
<p><b>1. Series</b>                      CLSV = Vertical Architecture                      CLSH = Horizontal Architecture (Profile rail size 15F only)                      CLSR = RoundRail Architecture</p> <p><b>2. Motor size</b>                      14 = NEMA 14 (CLSV rail size 9, 12 only)                      17 = NEMA 17                      23 = NEMA 23</p> <p><b>3. Motor stack</b>                      A = Single                      B = Double</p> <p><b>4. Motor current rating (in 0.1 amps)</b>                      13 = 1.3 amps                      15 = 1.5 amps                      19 = 1.9 amps                      30 = 3.0 amps</p> <p><b>5. Screw diameter</b>                      31 = 0.3125 in      M08 = 8.0 mm                      37 = 0.3750 in      M10 = 10.0 mm</p> <p><b>6. Linear travel/rev</b>                      0050 = 0.050 in      020 = 2.0 mm                      0063 = 0.063 in      030 = 3.0 mm                      0079 = 0.079 in      040 = 4.0 mm                      0083 = 0.083 in      050 = 5.0 mm                      0100 = 0.100 in      060 = 6.0 mm                      0125 = 0.125 in      080 = 8.0 mm                      0167 = 0.167 in      100 = 10.0 mm                      0200 = 0.200 in      120 = 12.0 mm                      0250 = 0.250 in      200 = 20.0 mm                      0300 = 0.300 in                      0375 = 0.375 in                      0500 = 0.500 in                      0750 = 0.750 in                      1000 = 1.000 in                      1200 = 1.200 in</p> <p><sup>(1)</sup> See below for the definition of orientation.  <sup>(2)</sup> Not compatible with NEMA 14 or CLSR.  <sup>(3)</sup> CLSH must use option F.</p>						<p><b>7. Accuracy grade</b>                      S = Standard 0.010 in/ft (250 µm/300 mm)                      P = Precision 0.003 in/ft (125 µm/300 mm)</p> <p><b>8. Stroke length</b>                      06000 = 6 in                      15000 = 150 mm (when metric diameter is selected)</p> <p><b>9. Lead screw coating</b>                      N = None                      T = PTFE</p> <p><b>10. Motor/Rail Orientation<sup>(1)</sup></b>                      X = For CLSV and CLSR                      L = Left (CLSH Only)                      R = Right (CLSH Only)</p> <p><b>11. Nut</b>                      MT = Flange Mount (MTS Series nut)                      FS = Triangular Flange, Anti-backlash (XC Series nut)</p> <p><b>12. Nut size</b>                      2 = 0.3125 in and 8 mm screws for MT nut                      3 = 0.3125 in and 8 mm screws for FS nut, 0.375 in and 10 mm screws for MT and FS nuts</p>						<p><b>13. Linear Bearing Type</b>                      P = Profile Rail (CLSV and CLSH)                      R = Roundrail (CLSR only)</p> <p><b>14. Linear Bearing Sizes</b>                      09 = Profile Rail, Size 9 (NEMA 14 only)                      12 = Profile Rail, Size 12 (NEMA 14, 17 only)                      15 = Profile Rail, Size 15                      06 = Round Rail, 3/8" (CLSR only)                      08 = Round Rail, 1/2" (CLSR only)</p> <p><b>15. Bearing Designation</b>                      A = Standard                      S = Super Smart (CLSR 08 bearing sizes only)                      C = Corrosion resistant (CLSR only)                      D = Super Smart + corrosion resistant (CLSR 08 bearing sizes only)                      F = 400 Series Profile Rail <sup>(2),(3)</sup> (Profile rail size 15 only)</p> <p><b>16. Limit Switches*</b>                      0 = No limit switches                      *Limit switches are not yet a standard offering, but can be provided - Please contact Thomson.</p> <p><b>17. Encoder*</b>                      XX = No Encoder                      * 400+ standard encoder options are available - Please contact Thomson to select one that best suits your application.</p> <p><b>18. Custom designation</b>                      (blank) = Standard configuration                      001-999 = Custom configuration</p>						

Right

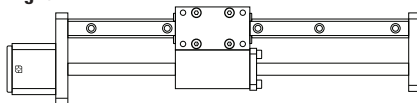

Left

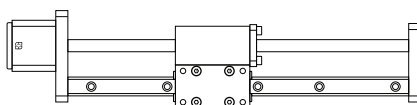



## Lead Screw Sizes

Inch Lead Screws			Diameter Designator [hundredths of in. diameter]	
Linear Travel / Full Step [ $\mu$ in]	Lead [in]	Lead Designator	31	37
0.250	0.050	0050		X
0.313	0.063	0063		X
0.394	0.079	0079		X
0.417	0.083	0083	X	X
0.500	0.100	0100		X
0.625	0.1235	0125		X
0.833	0.167	0167	X	X
1.000	0.200	0200		X
1.250	0.250	0250	X	X
1.500	0.300	0300		X
1.875	0.375	0375		X
2.500	0.500	0500	X	X
3.750	0.750	0750		X
5.000	1.000	1000	X	X
6.000	1.200	1200		X
Metric Lead Screws			Diameter Designator	
Linear Travel / Full Step [ $\mu$ m]	Lead [mm]	Lead Designator	M08	M10
10	2.0	020	X	X
15	3.0	030		X
20	4.0	040	X	
25	5.0	050		X
30	6.0	060		X
40	8.0	080	X	
50	10.0	100		X
60	12.0	120	X	X
100	20.0	200	X	X

# Specifications

Basic Specifications			
Lead Screw			
Material		300 Series Stainless Steel	
Standard Coating <sup>1</sup>		None	
Standard Lead Accuracy	[in./ft. (μm/300 mm)]	0.010 (250)	
Precision Lead Accuracy	[in./ft. (μm/300 mm)]	0.003 (75)	
Straightness	[in./ft. (μm/300 mm)]	0.005 (125)	
Lead Nut			
Standard Material		Internally lubricated acetal	
Nut Efficiency <sup>2</sup>	[%]	Up to 85	
Typical Linear Travel Life	[in. (km)]	10 x 10 <sup>6</sup> (250)	
Positional Repeatability with Standard Nut <sup>3</sup>	[in. (mm)]	0.005 to 0.010 (0.127 to 0.254)	
Positional Repeatability with Anti-Backlash Nut <sup>4</sup>	[in. (mm)]	<0.002 (0.051)	
Motor			
Frame Size		NEMA 14	NEMA 17
Step Size	[°]	1.8	
Concentricity of Mounting Pilot to Shaft	[in. (mm)]	0.003 (0.08) TIR	
Perpendicularity of Shaft to Mounting Face	[in. (mm)]	0.003 (0.08) TIR	
Max. Case Temperature	[°F (°C)]	176 (80)	
Storage Temperature	[°F (°C)]	-4 to 122 (-20 to 50)	
Ambient Temperature	[°F (°C)]	-4 to 122 (-20 to 50)	
Max. Humidity (non-condensing)	[%]	85	
Magnet Wire Insulation	[°F (°C)]	Class B 130 (266)	
Insulation Resistance		@ 500 VDC [Mohm] 100	
Dielectric Strength		for 1 min. [Vac] 500	
Assembly			
Max. Backlash with Standard Nut <sup>5</sup>	[in. (mm)]	0.010 (0.25)	
Operating Temperature	[°F (°C)]	15 to 125 (-10 to 50)	

1. Contact Thomson for optional lead screw coatings.

2. Depends on lead, nut material and lubrication.

3. Depends on nut, load and orientation.

4. For best positional repeatability, load should be kept well below design system.

5. Nut fit can be adjusted depending on backlash requirements.



## Specifications – Encoders

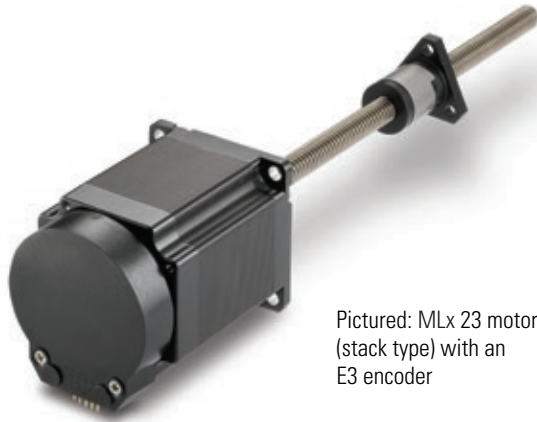

Pictured: MLx 23 motor (stack type) with an E3 encoder



### Features and Benefits

- All CLS configurations are available with rear-mounted optical encoders
- Two channel quadrature square wave outputs with optional third channel index output
- Various cycles per revolution (CPR) or pulses per revolution (PPR) available – from 32 to 10,000 CPR or 128 to 40,000 PPR

### Encoders

Motor Size	E2	E3	E5	E6
NEMA 14	•		•	
NEMA 17	•	•	•	•
NEMA 23		•		•

### Available Configurations

Motors	Encoder	Cycles Per Revolution (CPR)	Index	Output
NEMA 14, NEMA 17	E2	32, 50, 96, 100, 192, 200, 250, 256, 360, 400, 500, 512, 540, 720, 900, 1000, 1024, 1250, 2000 <sup>1</sup> , 2048 <sup>1</sup> , 2500 <sup>1</sup> , 4000 <sup>1</sup> , 4096 <sup>1</sup> , 5000 <sup>1</sup>	Index or No Index	N/A
NEMA 17, NEMA 23	E3	64, 100, 200, 400, 500, 512, 1000, 1024, 1800, 2000, 2048, 2500, 3600 <sup>1</sup> , 4000 <sup>1</sup> , 4096 <sup>1</sup> , 5000 <sup>1</sup> , 7200 <sup>1</sup> , 8000 <sup>1</sup> , 8192 <sup>1</sup>		
NEMA 14, NEMA 17	E5	32, 50, 96, 100, 192, 200, 250, 256, 360, 400, 500, 512, 540, 720, 900, 1000, 1024, 1250, 2000 <sup>1</sup> , 2048 <sup>1</sup> , 2500 <sup>1</sup> , 4000 <sup>1</sup> , 4096 <sup>1</sup> , 5000 <sup>1</sup>		Single-Ended or Differential
NEMA 17, NEMA 23	E6	64, 100, 200, 400, 500, 512, 1000, 1024, 1800, 2000, 2048, 2500, 3600 <sup>1</sup> , 4000 <sup>1</sup> , 4096 <sup>1</sup> , 5000 <sup>1</sup> , 7200 <sup>1</sup> , 8000 <sup>1</sup> , 8192 <sup>1</sup> , 10000 <sup>1</sup>		

1. CPR available with Index only

Note: Please specify encoder model, CPR, Index and Output (if applicable)

# Dimensions – Encoders

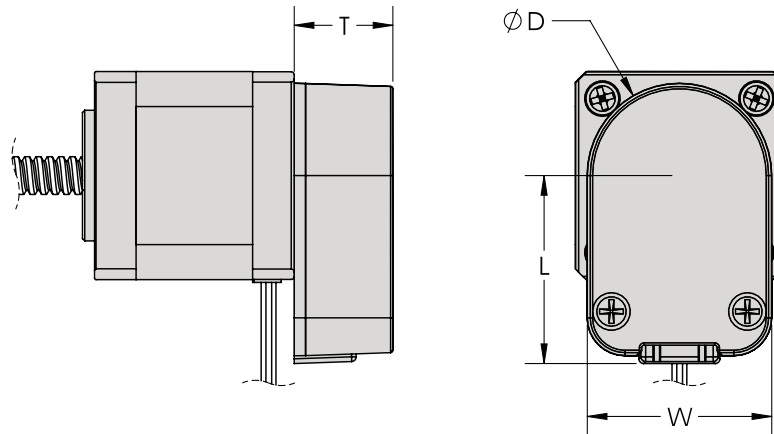

## Encoder Specifications

Encoder	Dimensions (inch)				Input/Output (VDC)			Operating Temperature (°C)		Acceleration (rad/sec <sup>2</sup> )	Mating Connector <sup>2</sup>	
	T <sup>1</sup>	L	D	W	Min	Typ	Max	Min	Max	Max	US Digital	
E2	0.62	0.82	1.19	1.19	4.5	5.0	5.5	-40	100	250,000	CON-C5 CON-LC5	
E3		0.57	2.20	1.62								
E5	0.65	1.24	1.22	1.22								-40 (CPR<2000) -25 (CPR≥2000)
E6		1.42	2.22	1.39								-40 (CPR<3600) -25 (CPR≥3600)

1. NEMA 17 motor requires mounting plate, which increases dimension T by approximately 0.15 in.
2. All single-ended encoders are 5 pin connections. All differential encoders are 10 pin connections.

## Pinouts

Pin	Single-Ended	Differential <sup>1</sup>
1	Ground	Ground
2	Index	
3	A Channel	Index-
4	+5 VDC Power	Index+
5	B Channel	A- Channel
6	-	A+ Channel
7	-	+5 VDC Power
8	-	
9	-	B- Channel
10	-	B+ Channel

1. E5 and E6 only

### SINGLE-ENDED

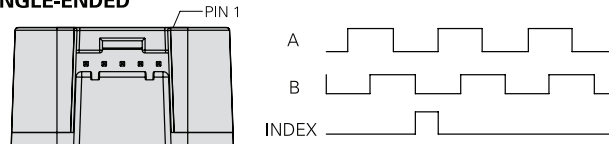

### DIFFERENTIAL

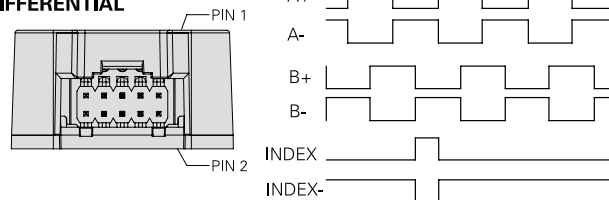



## Wiring and Connectors

Thomson offers standard wiring and connector pin-outs (shown below). However, if you have unique application requirements such as a specific mating connector you'd like to easily plug into, we also offer custom wiring and connectors to match your needs. Just contact us with your request, and we'll find a solution.

### NEMA 14, NEMA 17 and NEMA 23

Flying Leads	
Lead Color	Phase
Red	A+
Blue	A-
Green	B+
Black	B-

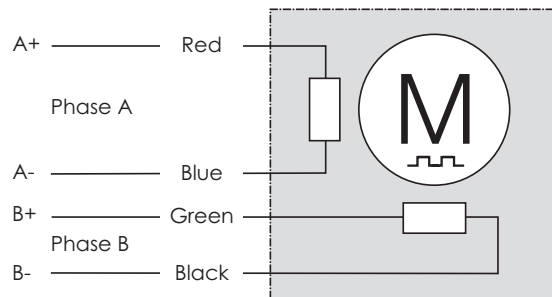

- Standard wiring diagram for NEMA 14, NEMA 17 and NEMA 23 configurations
- 26 AWG lead wires for NEMA 14
- 22 AWG lead wires for NEMA 17 and NEMA 23
- Other lead wire gauges available - contact Thomson for more details



Contact us or any of our 2000+ global distribution partners by scanning the code below  
or visiting [www.thomsonlinear.com/contact](http://www.thomsonlinear.com/contact)



**RegalRexnord™**

[www.regalrexnord.com](http://www.regalrexnord.com)

[www.thomsonlinear.com](http://www.thomsonlinear.com)

Compact\_Linear\_Systems\_BREN-0038-07 | 20260223KB | MCB-12427-TL-EN-US 02/26  
Specifications are subject to change without notice. It is the responsibility of the product user to determine  
the suitability of this product for a specific application. All trademarks property of their respective owners.  
©2026 Thomson Industries, Inc. | 2400 Curtiss Street, Downers Grove, IL 60515 USA

**THOMSON®**